

PRODUCT DESCRIPTION

Elevate the game with StraightLine B3 Doors, designed for both security and style! These doors provide enhanced security with an anti-tampering keyless combination lock, ensuring safe storage during events. Designed with a sleek, modern aesthetic, they seamlessly integrate with StraightLine & BrightLine modular displays for a flawless fit. Featuring One Planet Graphics, these doors come fully branded with double-sided graphics to maximize visual impact.

Their tool-free, hassle-free setup allows for quick assembly, while the collapsible design enables easy packing into foam-lined shipping cases for superior portability. Combining security, style, and convenience, StraightLine B3 Doors enhance any professional display setup.

DISPLAY CONSTRUCTION

Aluminum frame with aluminum support poles

DIMENSIONS

Assembled Unit	40"w x 89"h x 4"d
Packed Case	46.5"w x 15"h x 8.7"d, 41 lbs
Shipping Box	47"w x 16"h x 10"d, 43 lbs
Graphic Size	40"w x 89"h

KEY FEATURES

- Modular system
- Easy tool free assembly
- Lightweight portable construction
- Anti-tampering keyless combination lock
- Heavy duty shipping case, molded foam inserts
- Includes 2 printed graphics
- Vibrant graphics on recycled fabric

GRAPHIC MATERIAL

Graphic Print : Dye sublimated on One Planet, 100% recycled, fabric	Bottles recycled 40
--	-------------------------------

GRAPHIC FINISHING

Silicone sewn edges

WARRANTY

- Limited Warranty Periods
- Frame : Lifetime
 - Graphics : 30 days

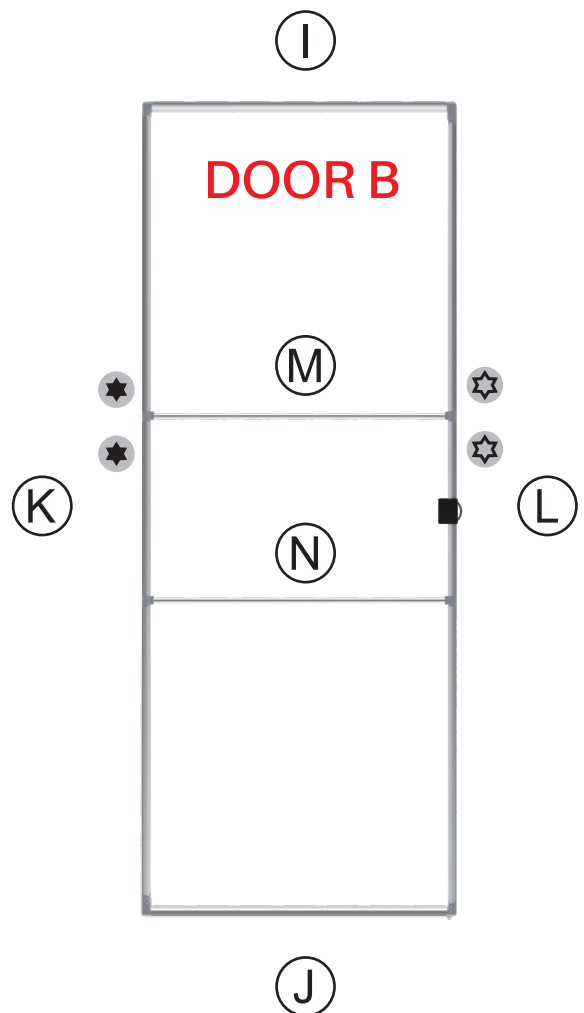
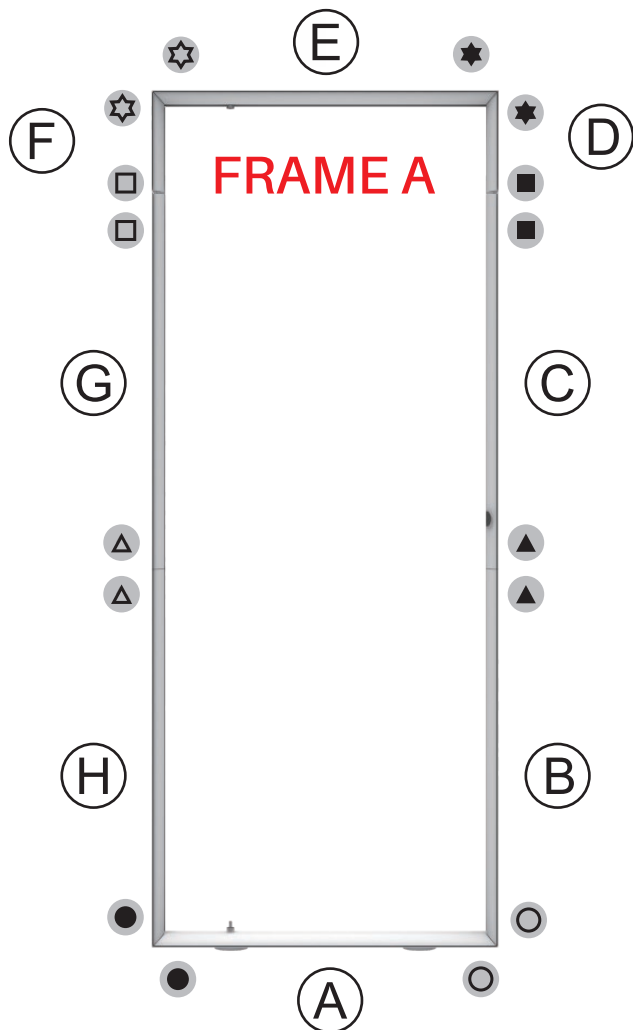
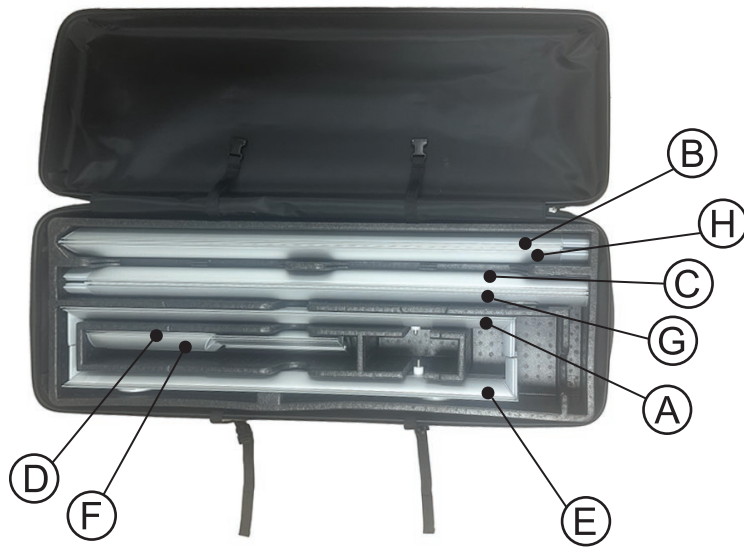

ASSEMBLY

Assemble parts on the floor and stand-up unit when completed.

1

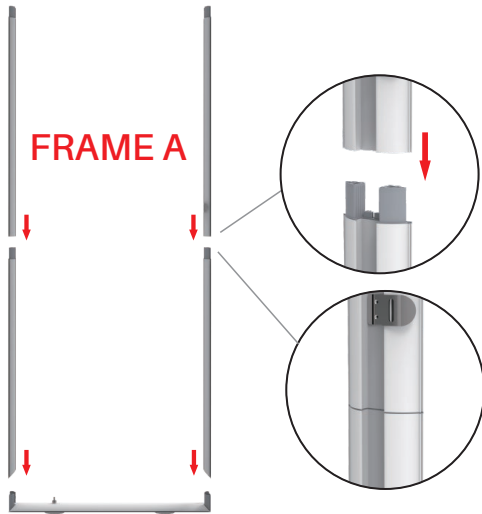

3

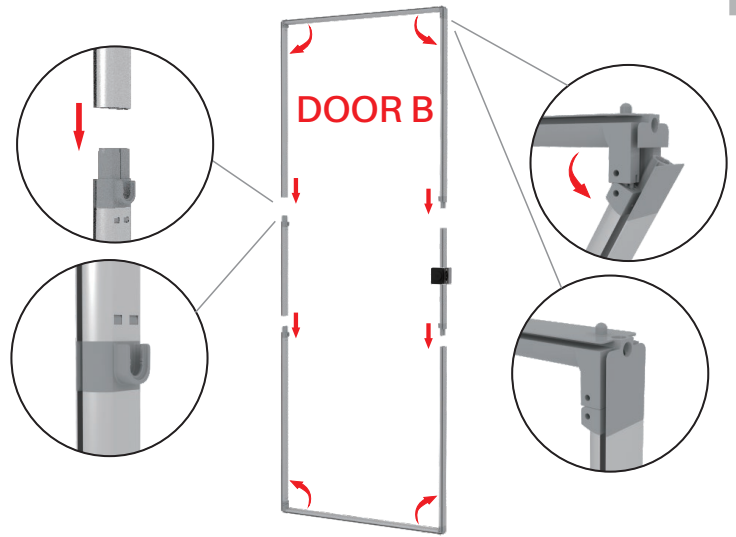

2

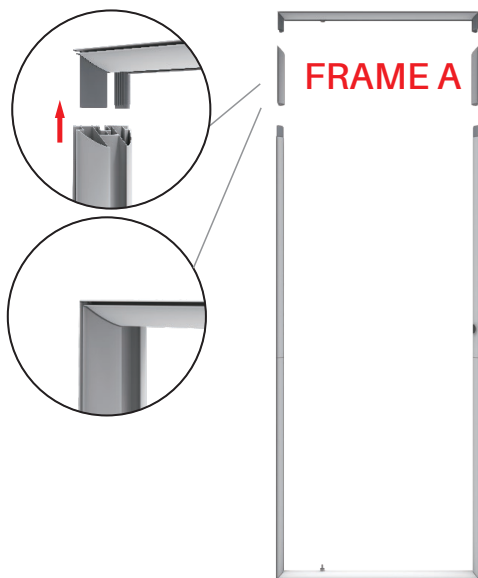

4

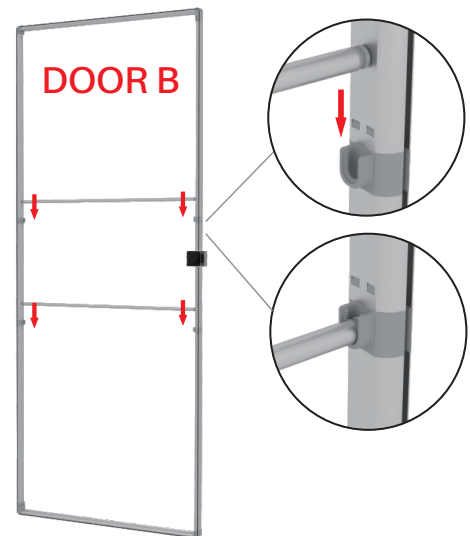

ASSEMBLY

Assemble parts on the floor and stand-up unit when completed.

5

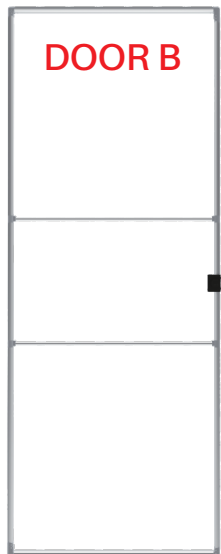

7



6

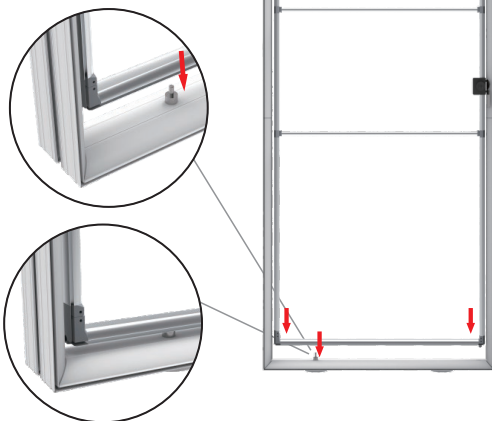

8



9 Push the silicone bead into each corner of the frame with your thumb.

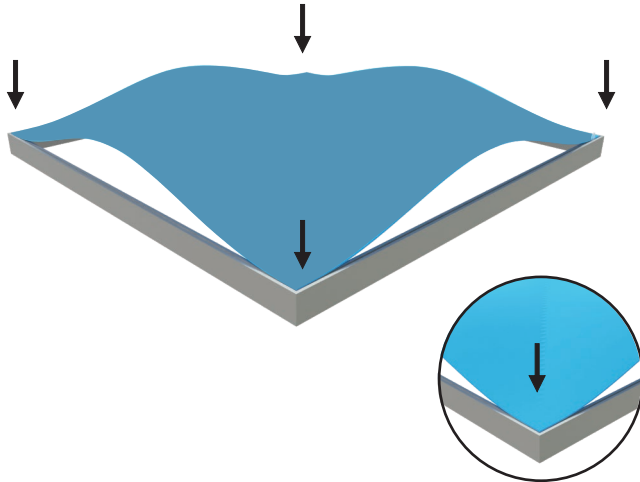

Push the silicone bead into the middle of the run and work your way around the perimeter of the frame until all beading is pushed in properly

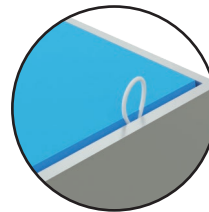
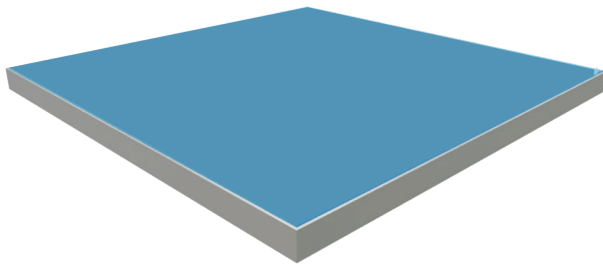
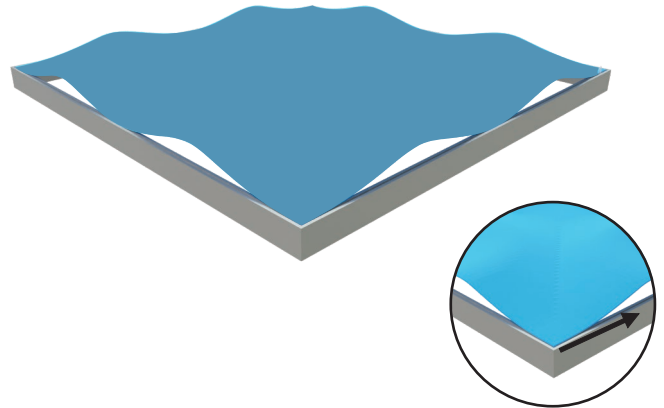

To Remove Graphic
Use the pull tab located on the graphic and gently pull the graphic from the frame, going around the perimeter

10



Turn to default passcode (000) and twist knob to unlocked position



Insert pin in the reset hole on the side and keep pressing while setting new passcode



Release and remove pin from hole